

PH series

六角肘节三通

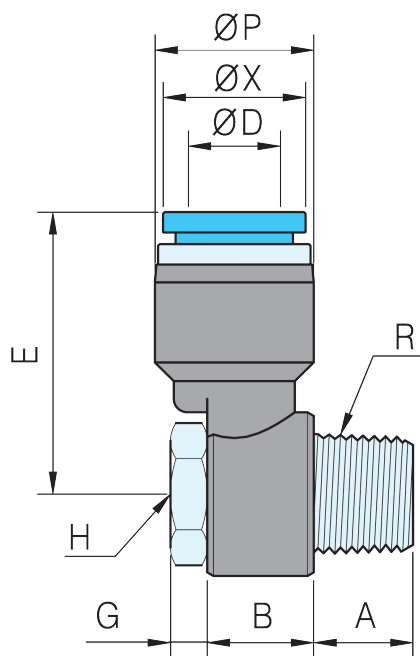

型号	ØD	R (Thread)	ØP	A	B	E	H	G	ØX	Q'TY/BOX
PH04M5	4	M5	11	4	9	22	8	3.5	10	50
PH0401		Rc1/8	11	7	12	22	12	3.5	10	50
PH0402		Rc1/4	11	9	11.8	24.4	14	4	10	50
PH06M5	6	M5	13	4	9	21.8	8	3.5	12	50
PH0601		Rc1/8	13	7	12	23	12	3.5	12	50
PH0602		Rc1/4	13	9	12	25.4	14	4	12	50
PH0603		Rc3/8	13	9	15.5	28.2	19	5	12	25
PH0604		Rc1/2	13	12	17.7	30	24	5	12	25
PH0801	8	Rc1/8	15	7	12	25	12	3.5	14	50
PH0802		Rc1/4	15	10	11.8	29	14	4	14	50
PH0803		Rc3/8	15	10	15.5	29	19	5	14	25
PH0804		Rc1/2	15	12	17.7	32	24	6	14	25
PH1001	10	Rc1/8	18.5	7	11.8	30	12	3.5	17	50
PH1002		Rc1/4	18.5	9	11.8	32.5	14	4.5	17	50
PH1003		Rc3/8	18.5	9	15.5	33	19	5	17	25
PH1004		Rc1/2	18.5	12	17.7	35	24	5.8	17	25
PH1202	12	Rc1/4	21	9	11.8	33	14	4.5	20	50
PH1203		Rc3/8	21	9	15.5	35	19	5	20	25
PH1204		Rc1/2	21	12	17.7	36.5	24	6	20	20